



480V:347V:277V Series

Step-Down Autotransformers for Lighting Applications

Features

- Input Voltage: 480V, 60 Hz or 347V, 60 Hz
- Output Voltage: 277V, 60 Hz
- Insulation Rating: 125 & 460– 105°C, 245– 130°C
- Non-isolated Autotransformer
- 5 Year Warranty - Industry Leading

Part Number	Losses	Input Current Max Load	Input Current No Load	Weight (lbs)
480:347:277-125VA	7W	0.26 A	0.070 A	2.3
480:347:277:220-245VA	10W	0.57 A	0.080 A	5.3
480:347:277-460VA	18W	0.95 A	0.220 A	7.2



Dimensions

Model	A (in)	B (in)	C (in)	D (in)	E (in)
125VA	See drawing below (mm)				
245VA	3.39	2.83	2.81	2.61	3.14
460VA	3.78	3.23	3.19	2.95	3.31

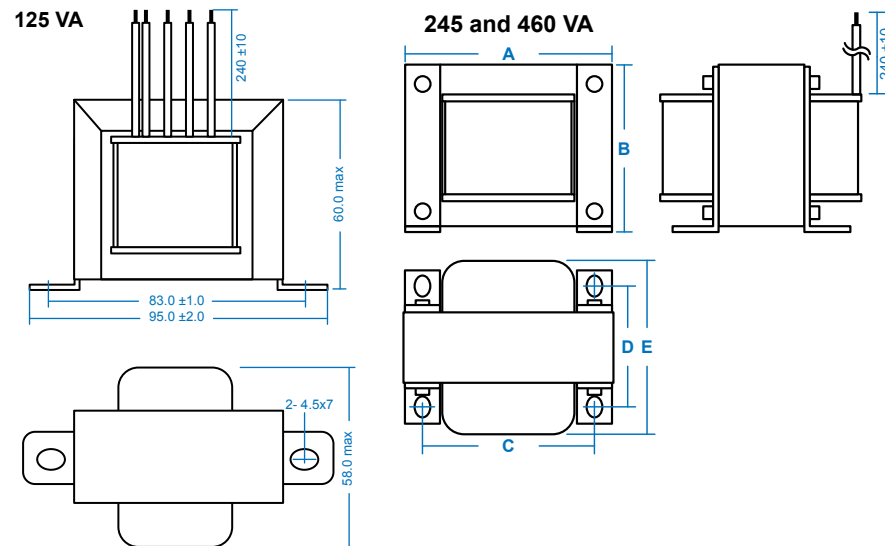

Step-down autotransformers designed especially for lighting applications, typically used with 277V LED Drivers, T-5 or T-8 Electronic Fluorescent Ballasts or Electronic HID Ballasts in Industrial and Commercial applications.

Wiring

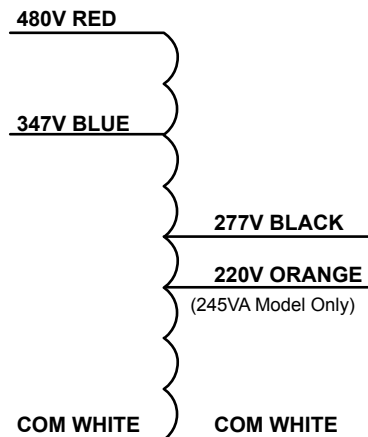

Wiring Notes:

- Wye 480V system—Connect red (or blue for 347V) and white wires to any two phase wires.
- Delta 480V—Connect to grounded referenced legs only.

